

TRAIL
IP67 \ IK08

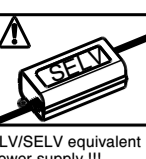

!!! use only SELV/SELV equivalent 24Vdc power supply !!!

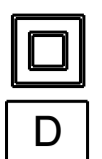

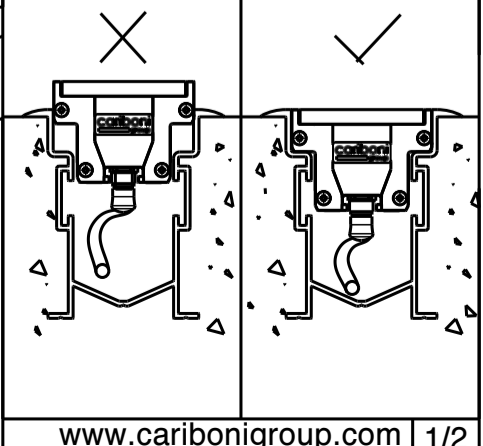
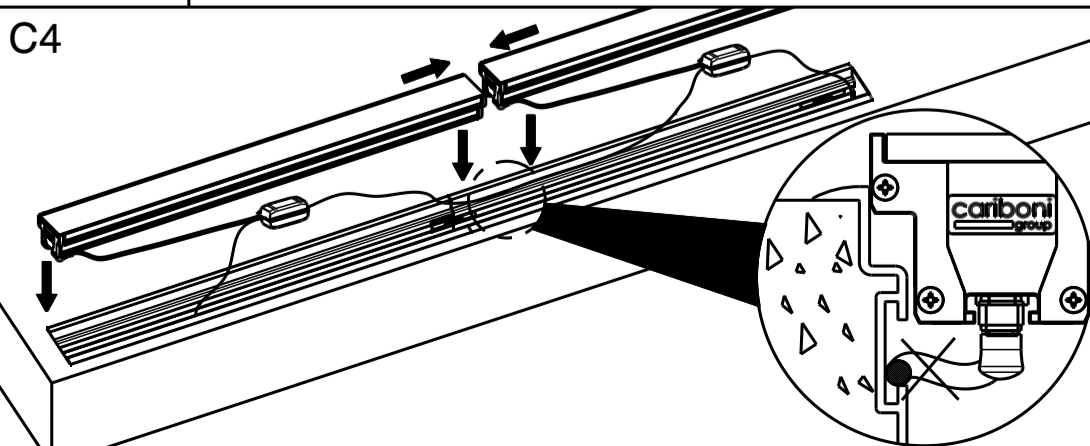
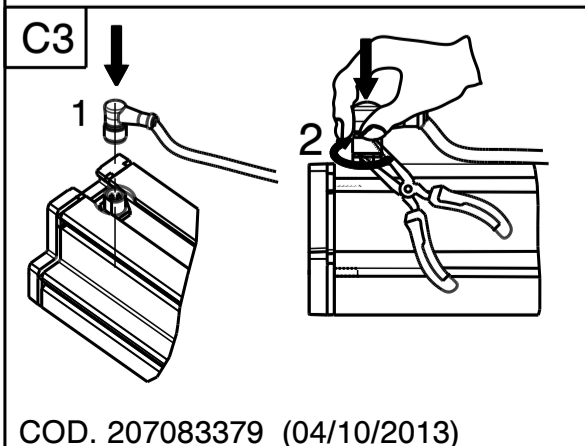
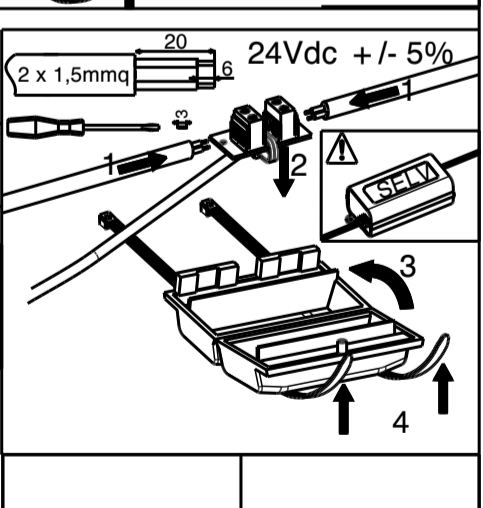
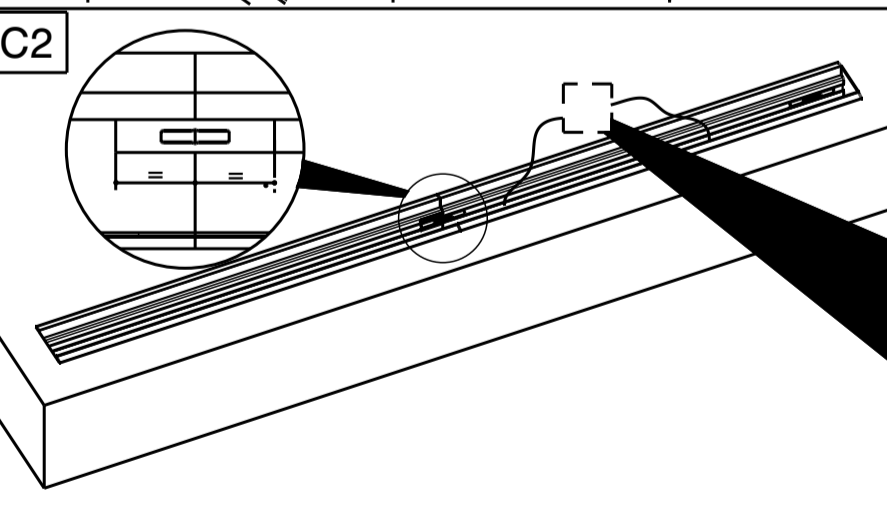
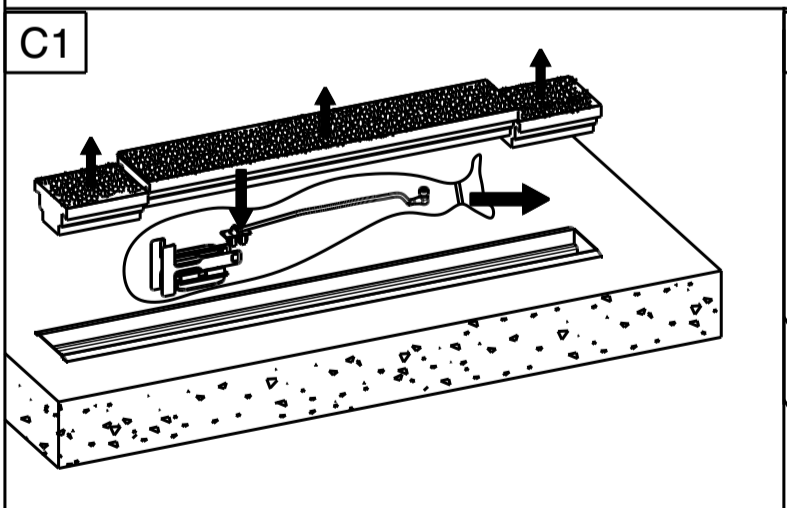
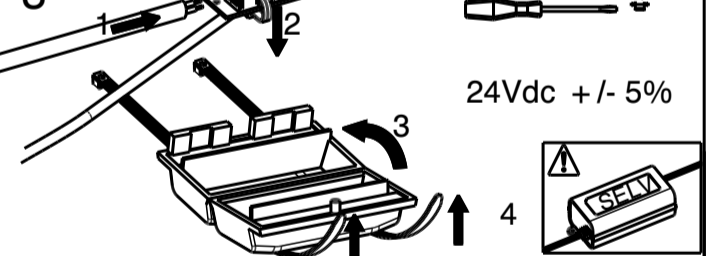
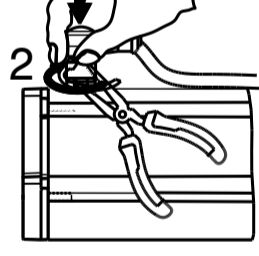
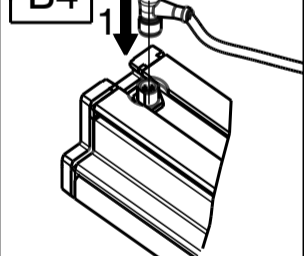
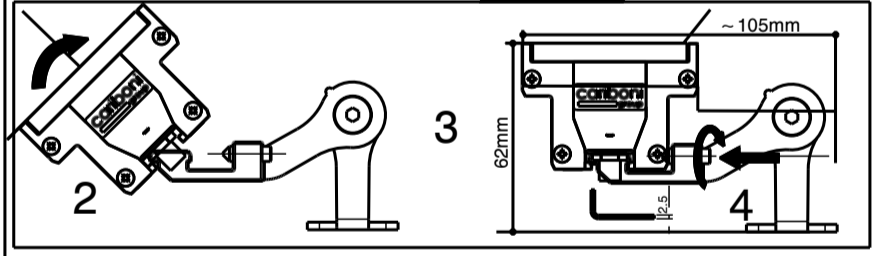
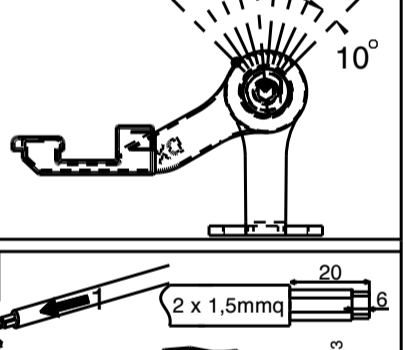
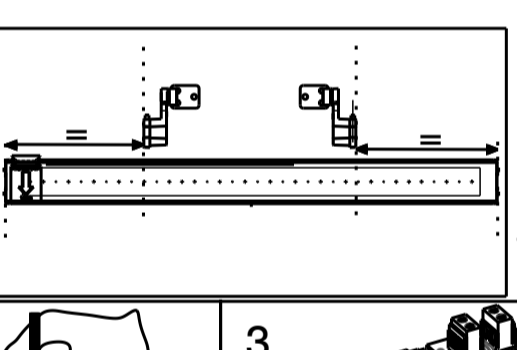
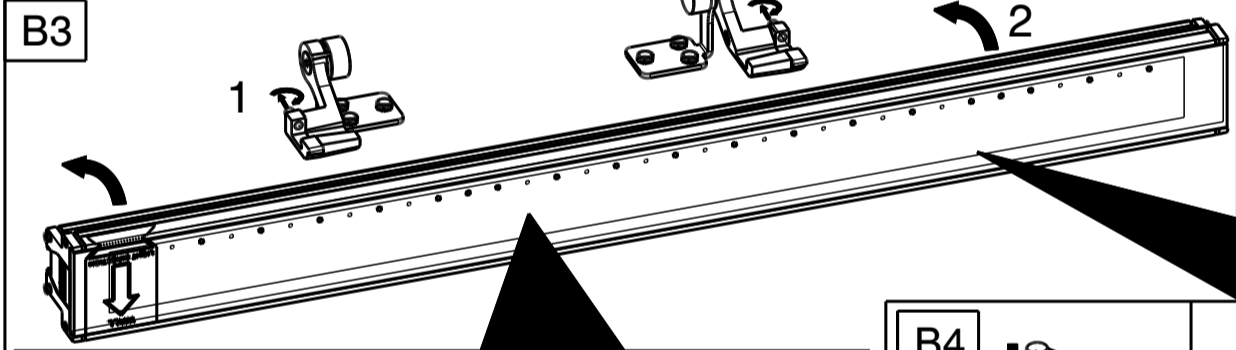
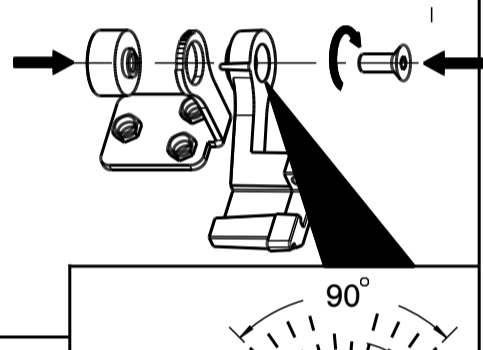
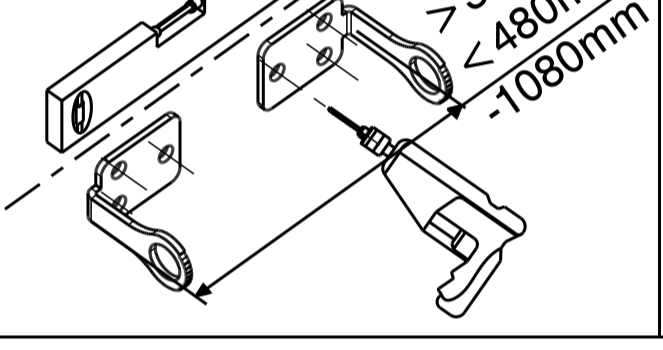
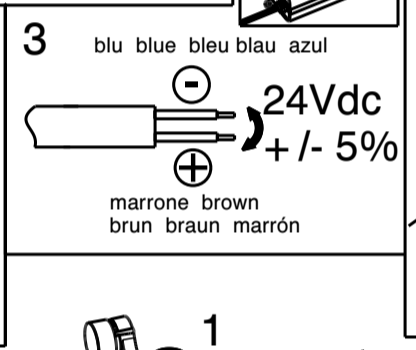
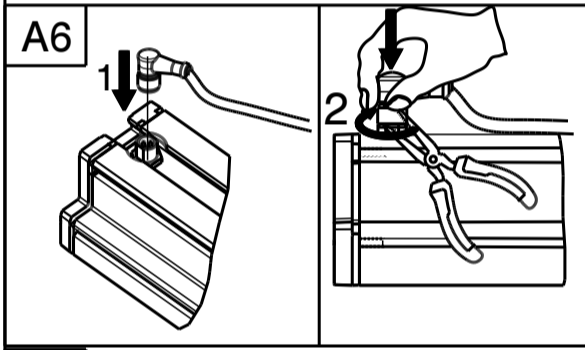
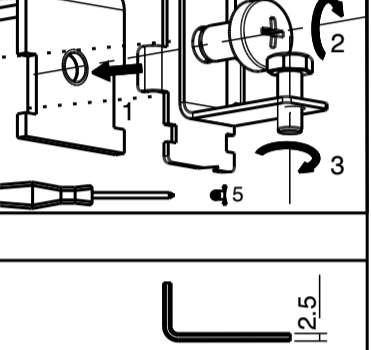
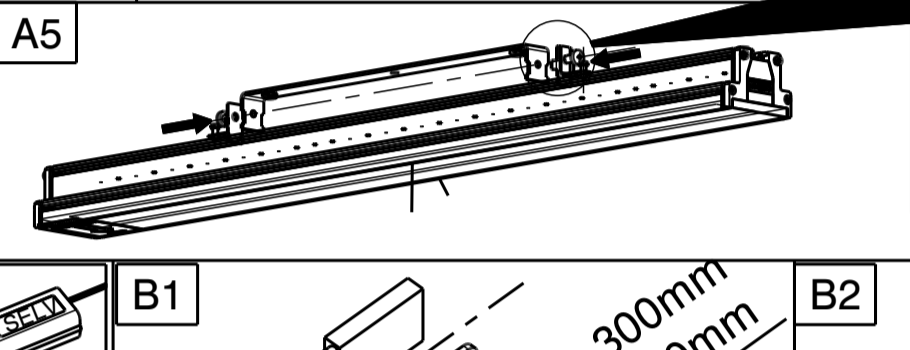
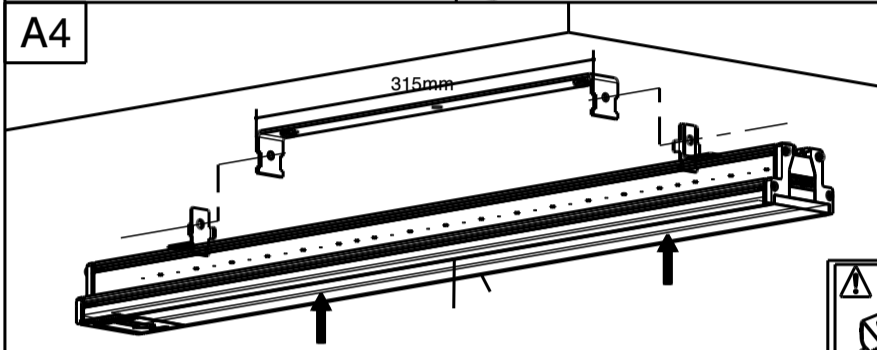
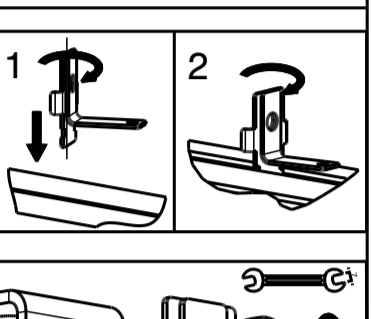
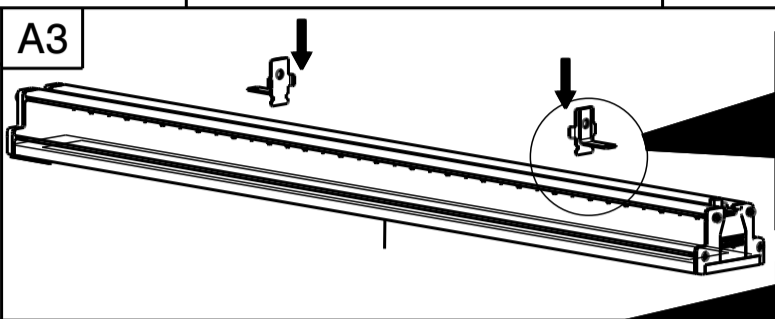
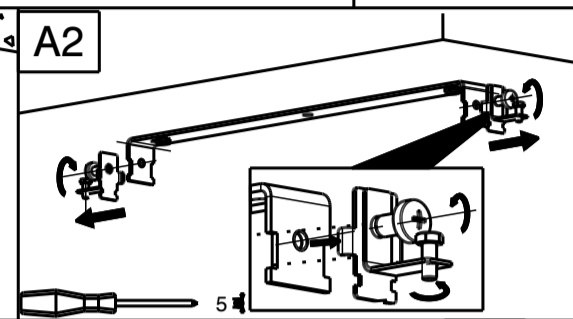
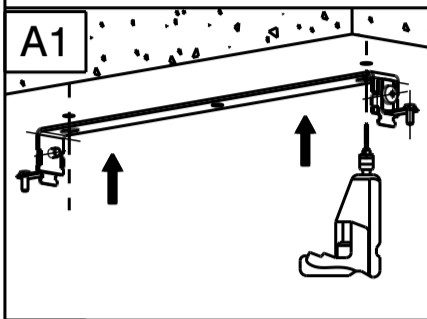
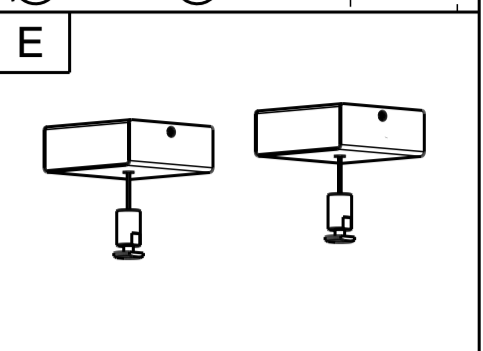
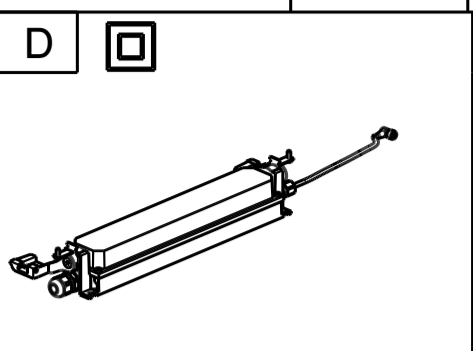
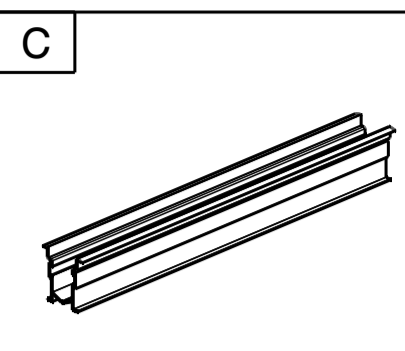
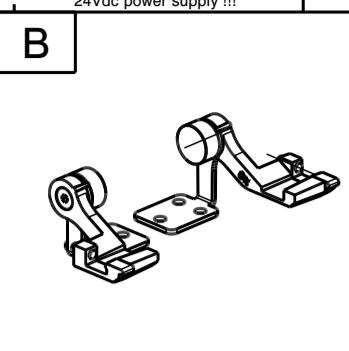
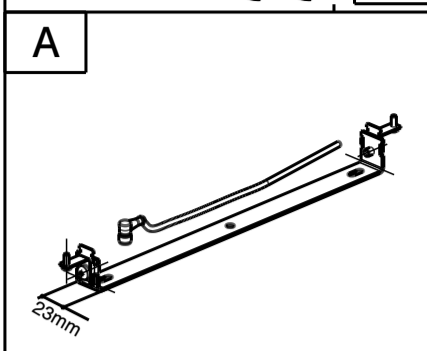
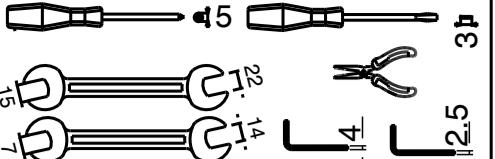
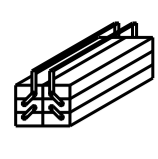
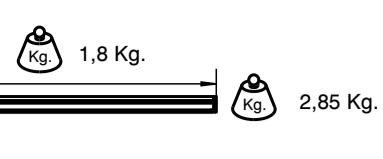
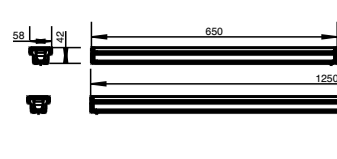
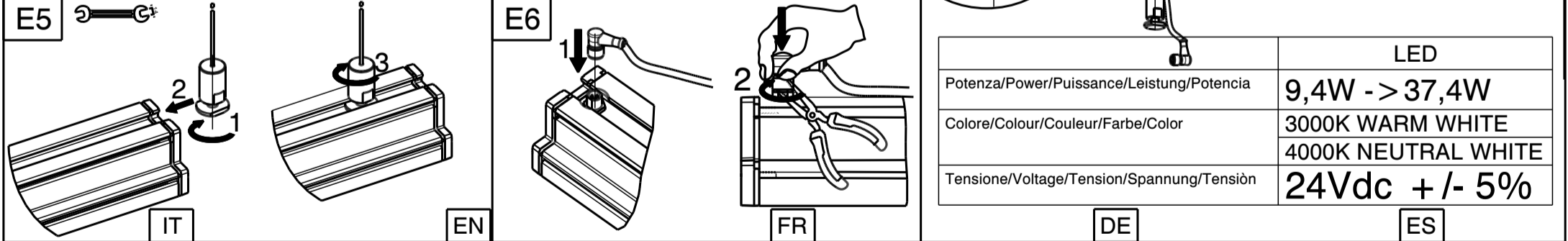
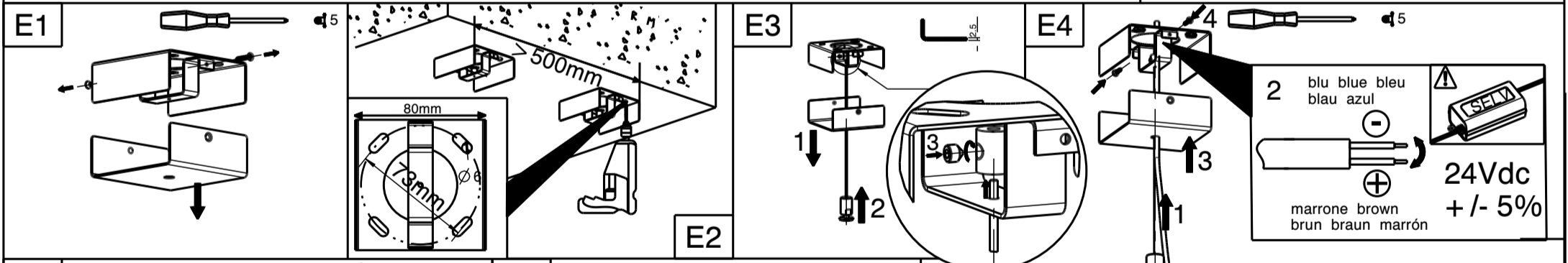
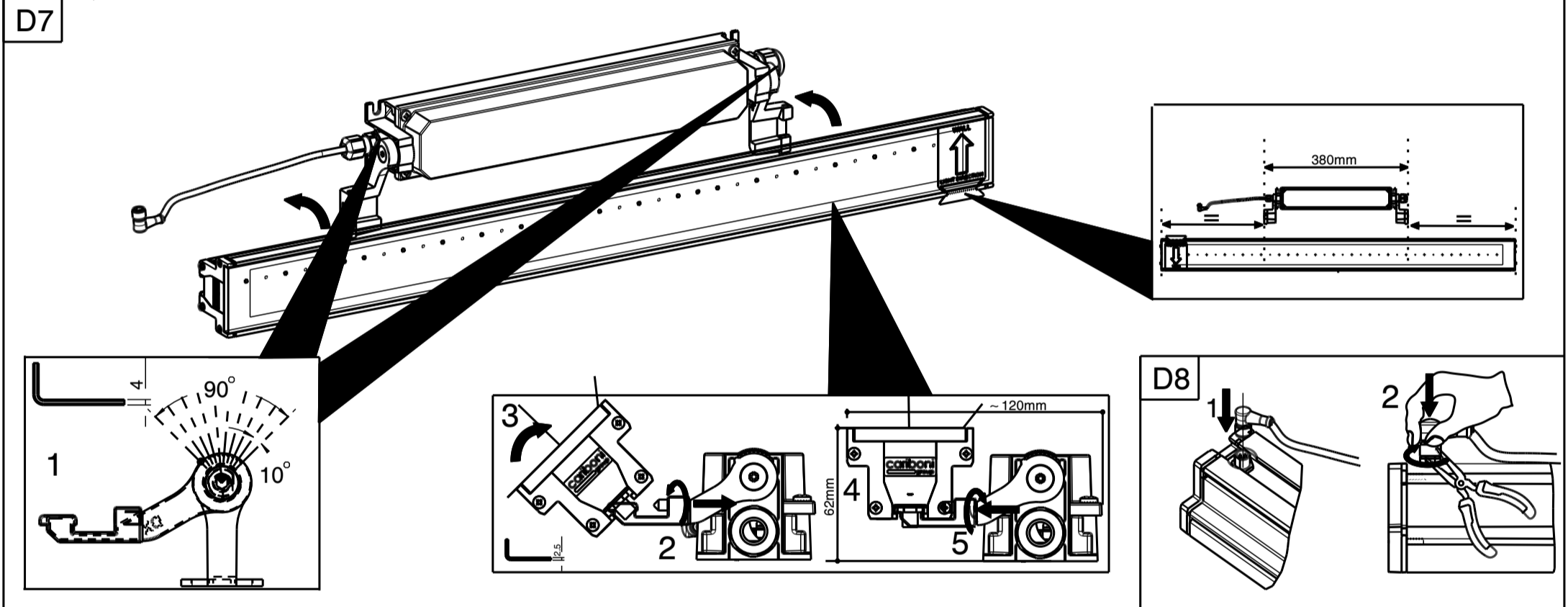
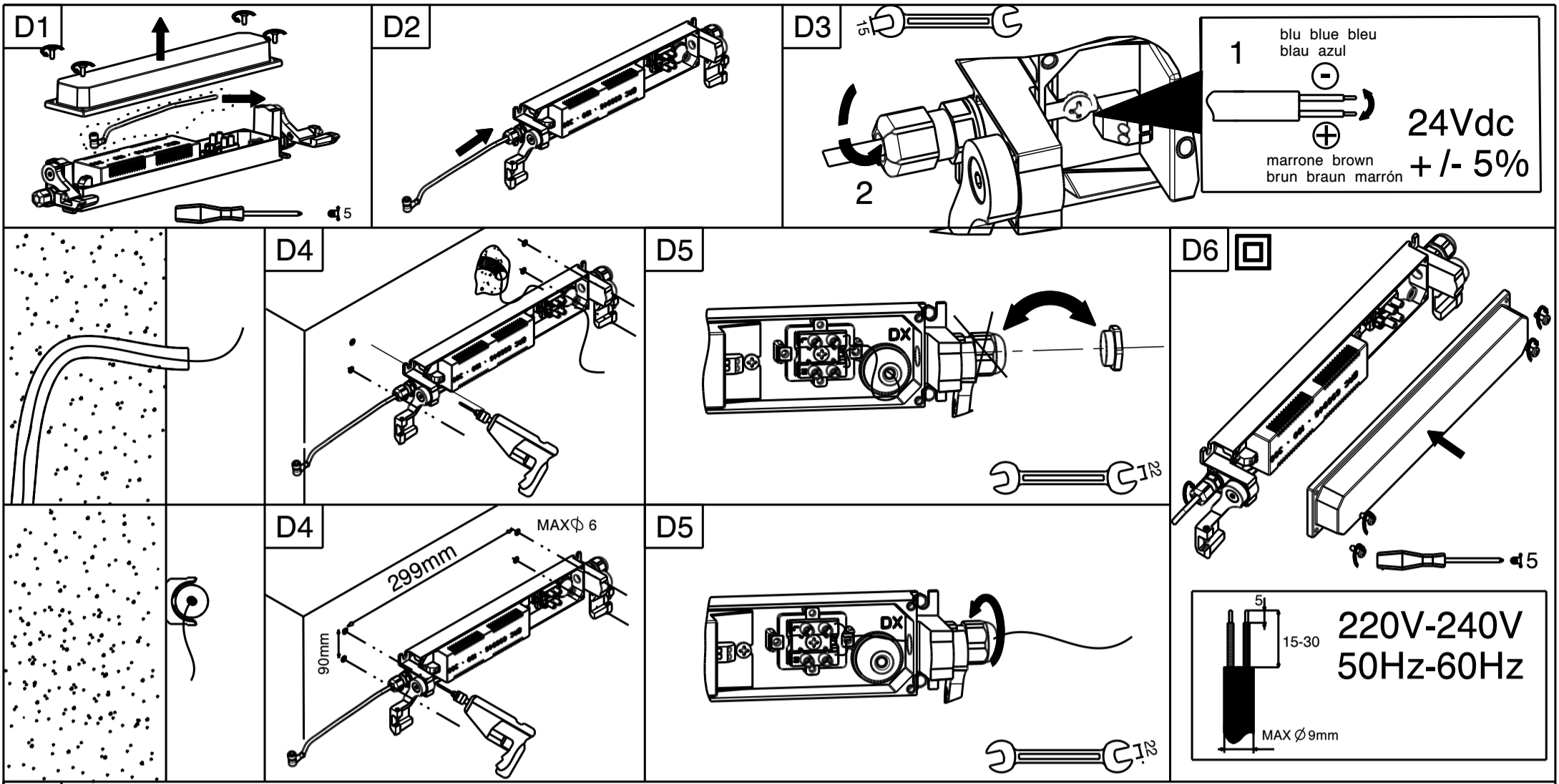

	LED
Potenza/Power/Puissance/Leistung/Potencia	9,4W -> 37,4W
Colore/Colour/Couleur/Farbe/Color	3000K WARM WHITE 4000K NEUTRAL WHITE
Tensione/Voltage/Tension/Spaltung/Tensión	24Vdc +/- 5%

IT Seguire attentamente le istruzioni per garantire un funzionamento corretto e sicuro. Conservare l'etichetta dell'imballo per consentire la rintracciabilità del lotto di produzione. In caso di reclamo il prodotto non deve essere modificato. Qualsiasi modifica annulla la garanzia e può rendere pericoloso il prodotto. Togliere tensione in caso di manutenzione. La Cariboni lite S.r.l. declina ogni responsabilità per i danni causati da un proprio prodotto montato in modo non conforme alle istruzioni.

EN Please carefully observe the instructions to achieve a correct and safe functioning. Please keep the packing label to enable the product lot identification in case of claim. Never modify the product. Any modification will cancel the guarantee and it can make the product dangerous. Please disconnect from supply net while replacing lamp or doing any maintenance. Cariboni lite S.r.l. declines any responsibility for damages, which can be caused by its own products if they are not assembled and installed in conformity with instructions.

FR Observer soigneusement les instructions afin d'assurer un fonctionnement correct et en sécurité. Garder l'étiquette de l'emballage pour permettre l'identification du lot de production en cas de litige. Ne jamais modifier le produit. Quelconque changement annule la garantie et peut rendre le produit dangereux. Déconnecter du réseau en cas de remplacement de la lampe ou entretien. Cariboni lite S.r.l. décline toute responsabilité pour les dommages causés par ses produits si assemblés et installés de façon non-conforme aux instructions.

DE Bitte Hinweisungen beachten, um einen korrekten und sicheren Betrieb zu gewährleisten. Aufheben Sie die Verpackungsetikette, um die Produktionspartie im Fall von Reklamation zu identifizieren. Das Gerät muss unbedingt nicht verändert werden; jede Änderung wird die Garantie des Produkts annullieren und kann das Gerät gefährlich machen. Bei der Ersetzung des Leuchtmittels, abnehmen Sie die Spannung. Cariboni Lite Srl erkennt keine Verantwortung für Schäden, die von solchen Produkten verursacht werden, die nicht gemäß diesen Montageanleitungen installiert wurden.

ES Seguir atentamente las instrucciones para garantizar un funcionamiento correcto y seguro. Conservar la etiqueta del embalaje para tener la información del lote de producción para cualquier reclamación. El producto no debe ser modificado. Cualquier cambio anula la garantía y puede hacer peligroso el producto. Cortar la alimentación para el cambio de la lámpara o para cualquier mantenimiento. Cariboni Lite, S.R.L. no acepta ninguna responsabilidad por daños causados por un producto montado de forma no conforme a las instrucciones.

Cornice per incasso a plafone e a parete TRAIL 650-1250

Recessed housing frame for ceiling and wall installation TRAIL 650-1250

Rahmen für die Wand- und Einbauinstallation TRAIL 650-1250

A) - 06TR988A0
B) - 06TR989A0

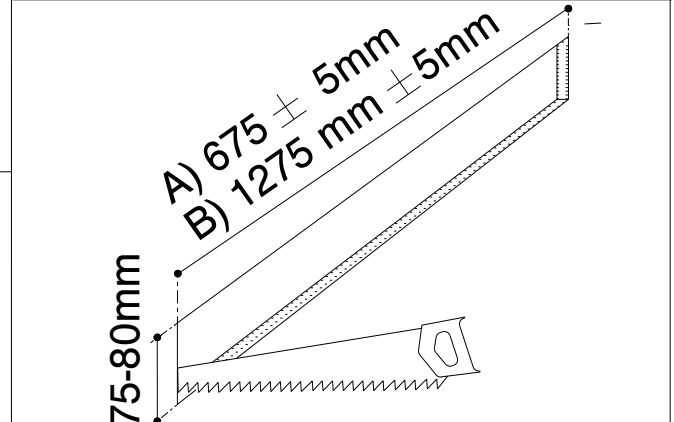
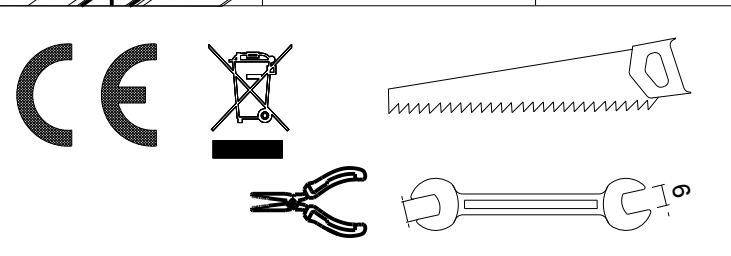
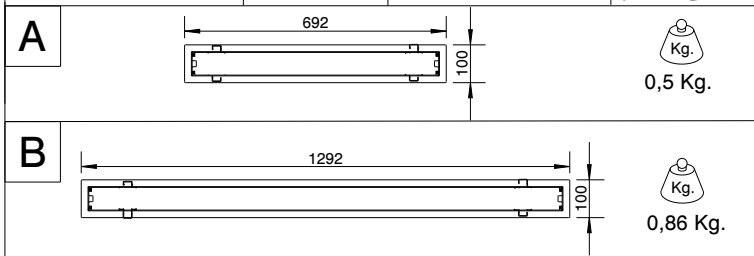
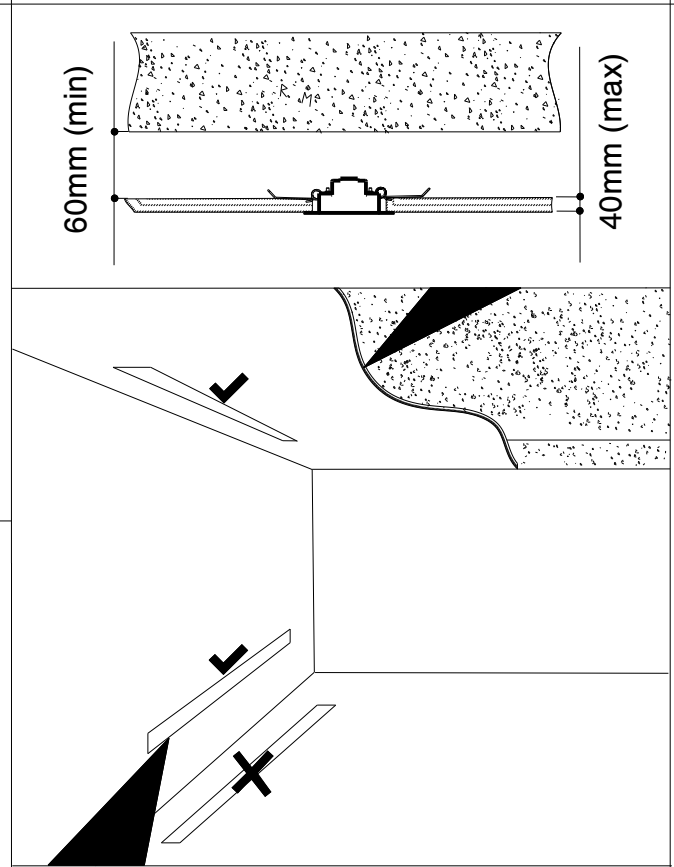
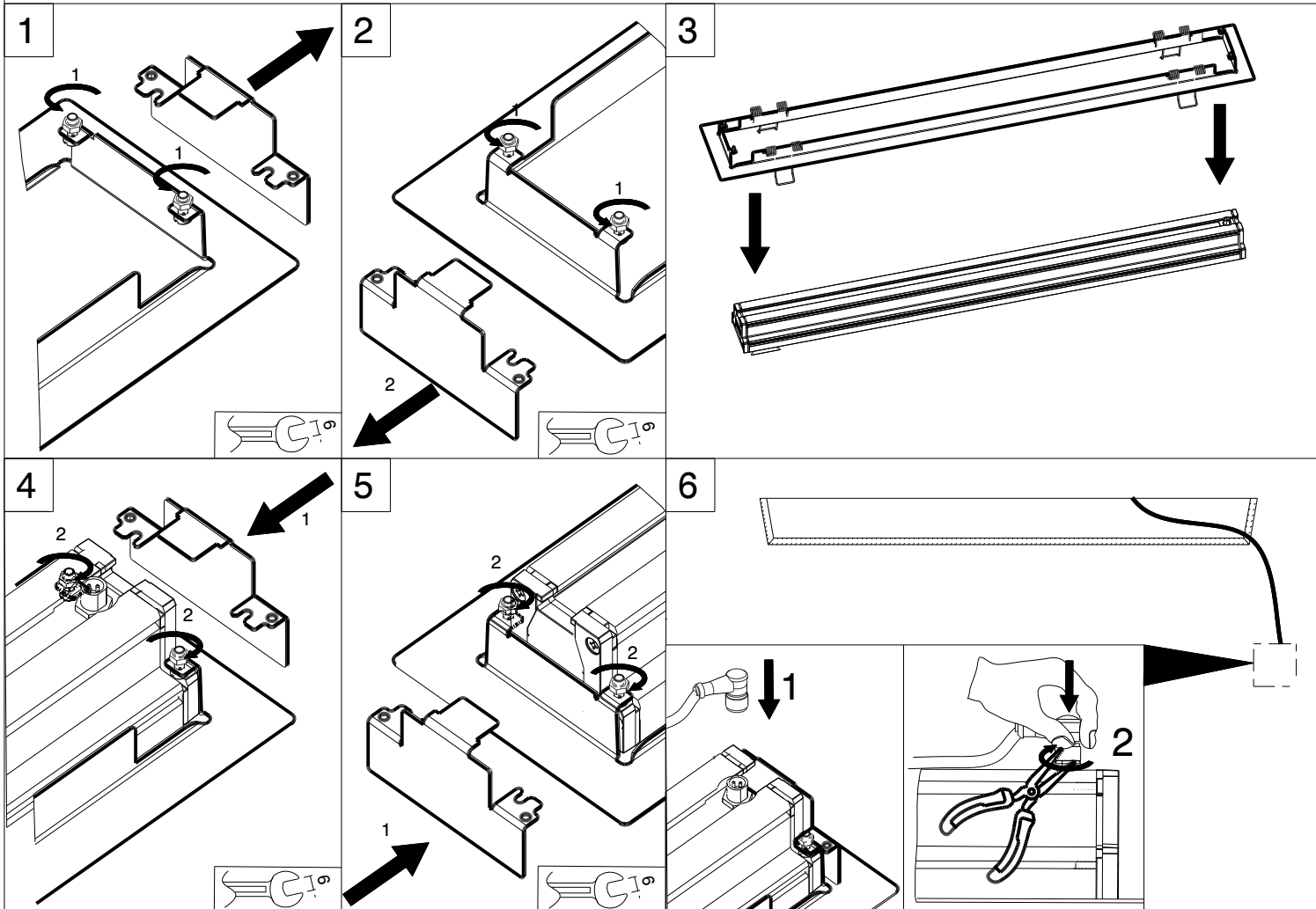

7

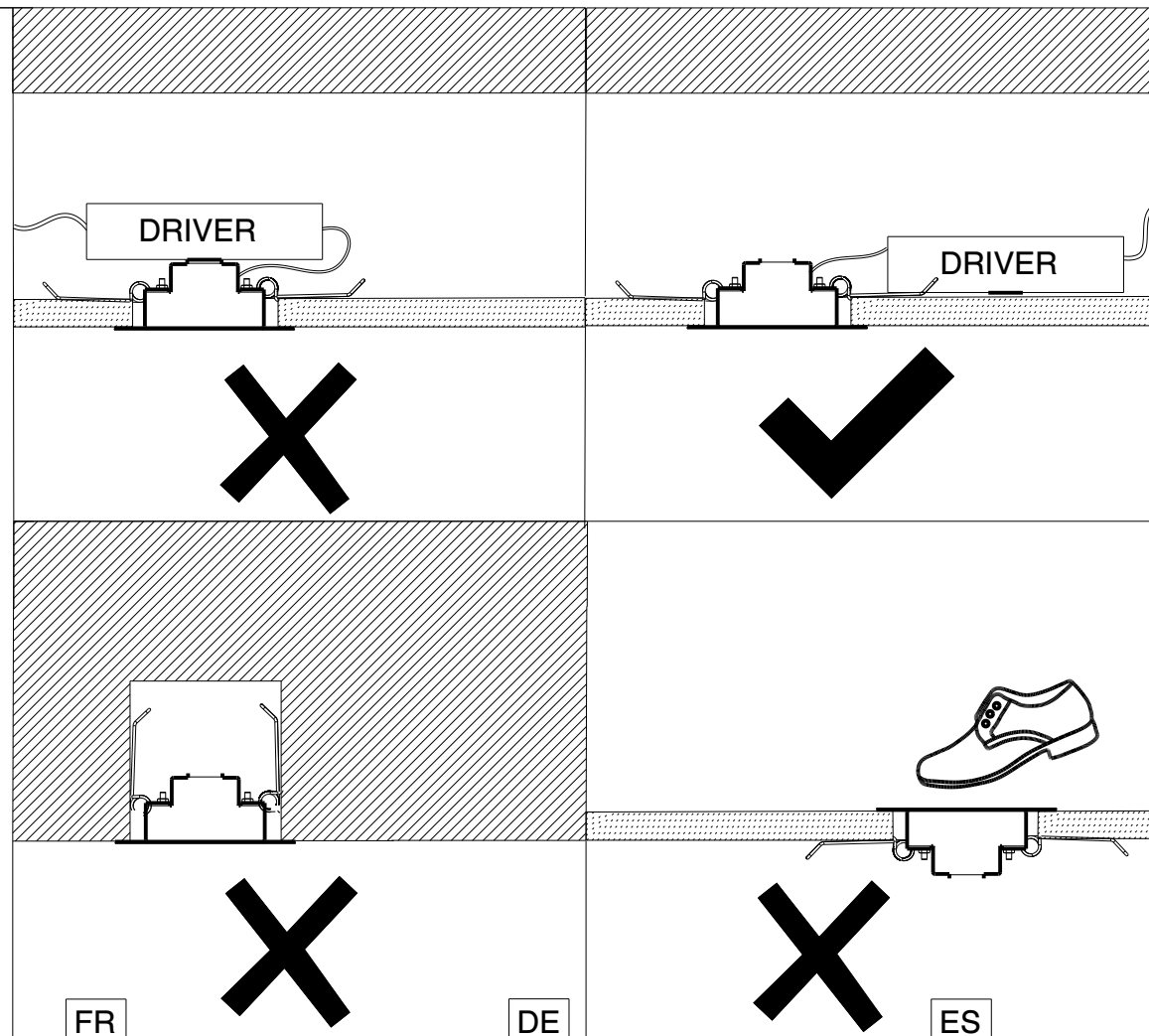
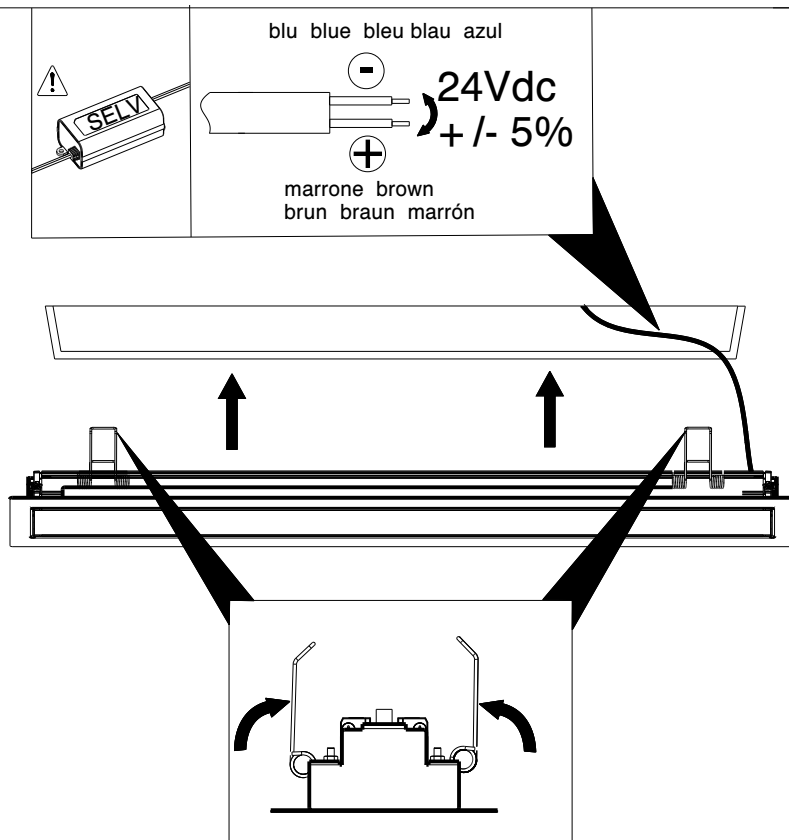

IT

Seguire attentamente le istruzioni per garantire un funzionamento corretto e sicuro. Conservare l'etichetta dell'imballo per consentire la rintracciabilità del lotto di produzione. In caso di reclamo il prodotto non deve essere modificato. Qualsiasi modifica annulla la garanzia e può rendere pericoloso il prodotto. Togliere tensione in caso di manutenzione. La Cariboni lite S.r.l. declina ogni responsabilità per i danni causati da un proprio prodotto montato in modo non conforme alle istruzioni.

EN

Please carefully observe the instructions to achieve a correct and safe functioning. Please keep the packing label to enable the product lot identification in case of claim. Never modify the product. Any modification will cancel the guarantee and it can make the product dangerous. Please disconnect from supply net while replacing lamp or doing any maintenance. Cariboni lite S.r.l. declines any responsibility for damages, which can be caused by its own products if they are not assembled and installed in conformity with instructions.

FR

Observer soigneusement les instructions afin d'assurer un fonctionnement correct et en sécurité. Garder l'étiquette de l'emballage pour permettre l'identification du lot de production en cas de litige. Ne jamais modifier le produit. Quelconque changement annule la garantie et peut rendre le produit dangereux. Déconnecter du réseau en cas de remplacement de la lampe ou entretien. Cariboni lite S.r.l. décline toute responsabilité pour les dommages causés par ses produits si assemblés et installés de façon non-conforme aux instructions.

DE

Bitte Hinweisungen beachten, um einen korrekten und sicheren Betrieb zu gewährleisten. Aufheben Sie die Verpackungsetikette, um die Produktionspartie im Fall von Reklamation zu identifizieren. Das Gerät muss unbedingt nicht verändert werden; jede Änderung wird die Garantie des Produkts annullieren und kann das Gerät gefährlich machen. Bei der Ersetzung des Leuchtmittels, abnehmen Sie die Spannung. Cariboni Lite Srl erkennt keine Verantwortung für Schäden, die von solchen Produkten verursacht werden, die nicht gemäß diesen Montageanleitungen installiert wurden.

ES

Seguir atentamente las instrucciones para garantizar un funcionamiento correcto y seguro. Conservar la etiqueta del embalaje para tener la información del lote de producción para cualquier reclamación. El producto no debe ser modificado. Cualquier cambio anula la garantía y puede hacer peligroso el producto. Cortar la alimentación para el cambio de la lámpara o para cualquier mantenimiento. Cariboni Lite, S.R.L. no acepta ninguna responsabilidad por daños causados por un producto montado de forma no conforme a las instrucciones.

VIA DELLA TECNICA 19
I-23875 OSNAGO (LC)
TEL. 039/587506
FAX 039/9520006

VIA PRATO 22
I-38068 ROVERETO (TN)
TEL. 0464/422247
FAX 0464/430393

VIA DELLA TECNICA 19
I-23875 OSNAGO (LC)
TEL. 039/9521.1
FAX 039/587812