

NEWTON

IP66

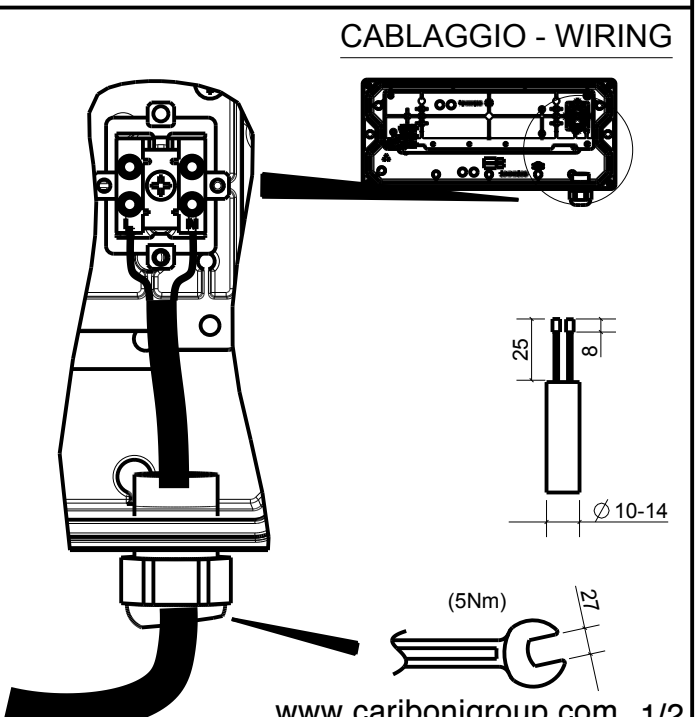

9 Kg.
SCX : 0,12 m²

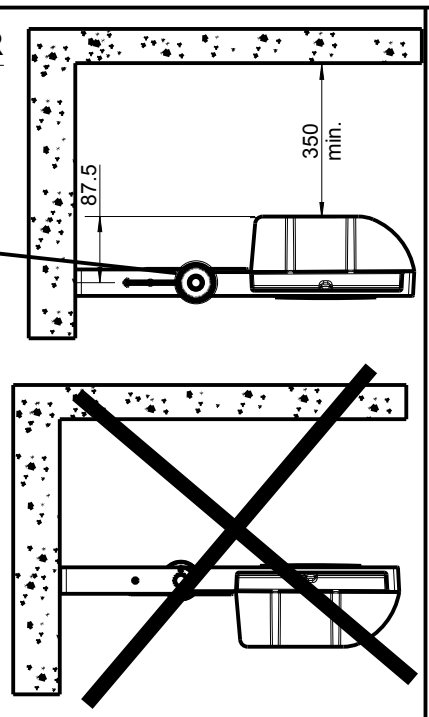
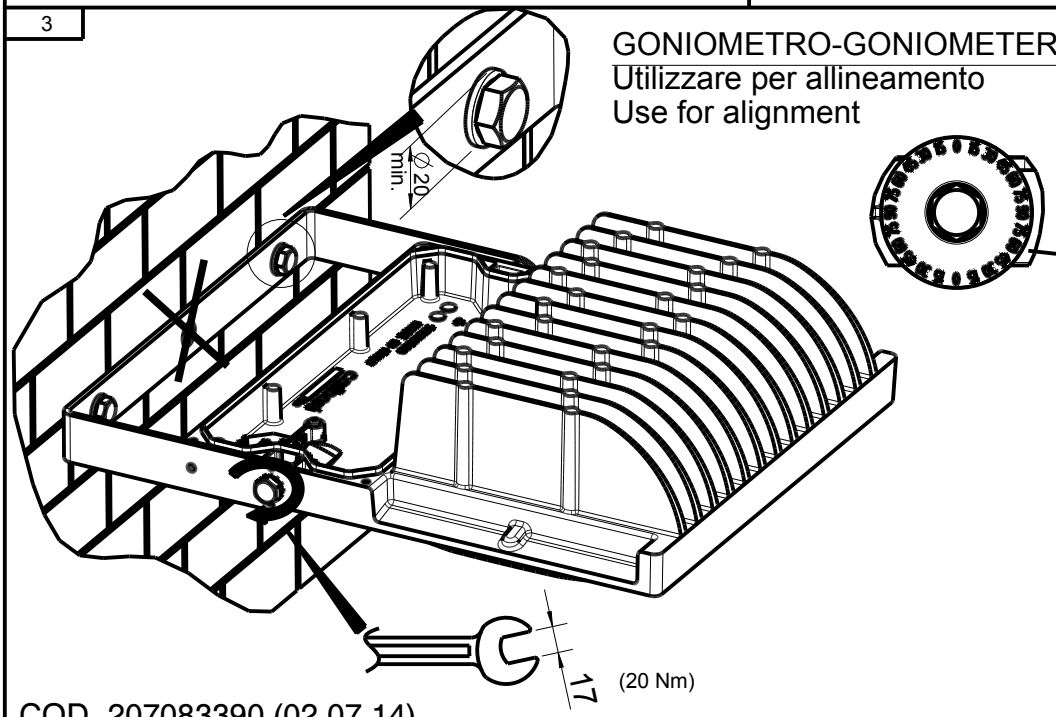
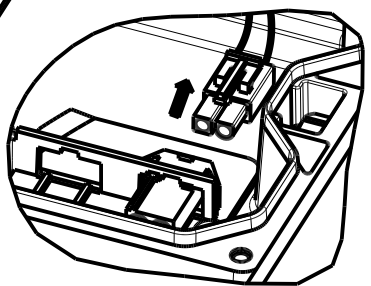
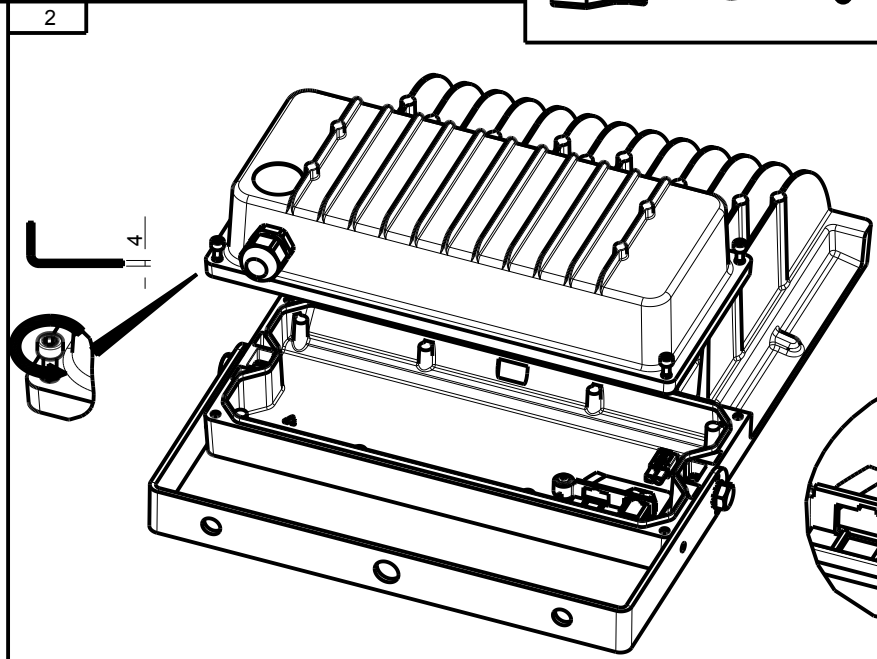
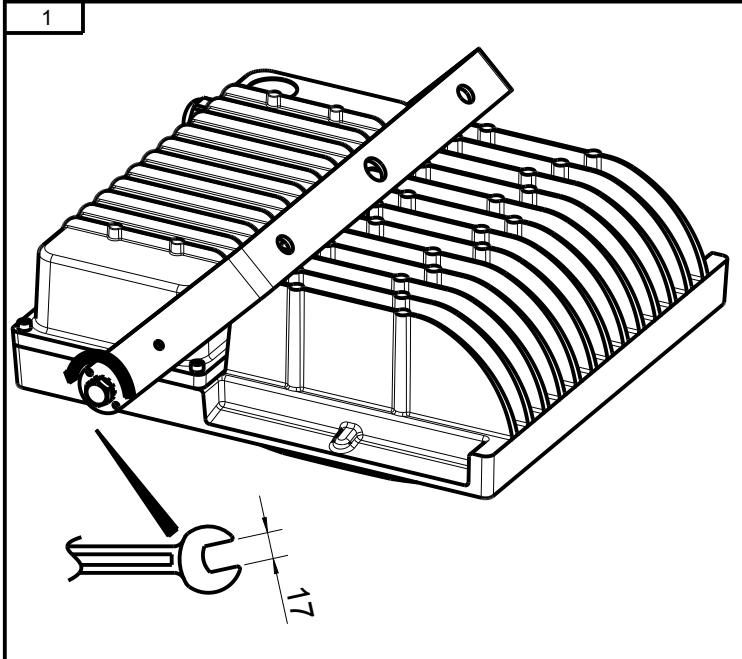
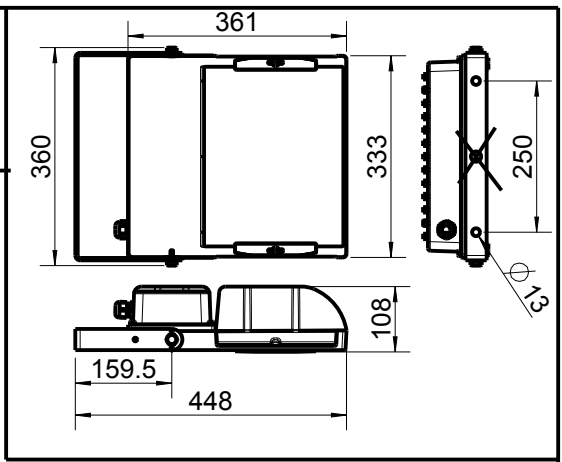
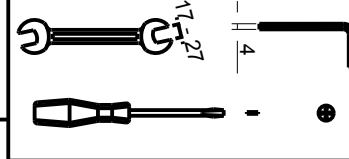

4

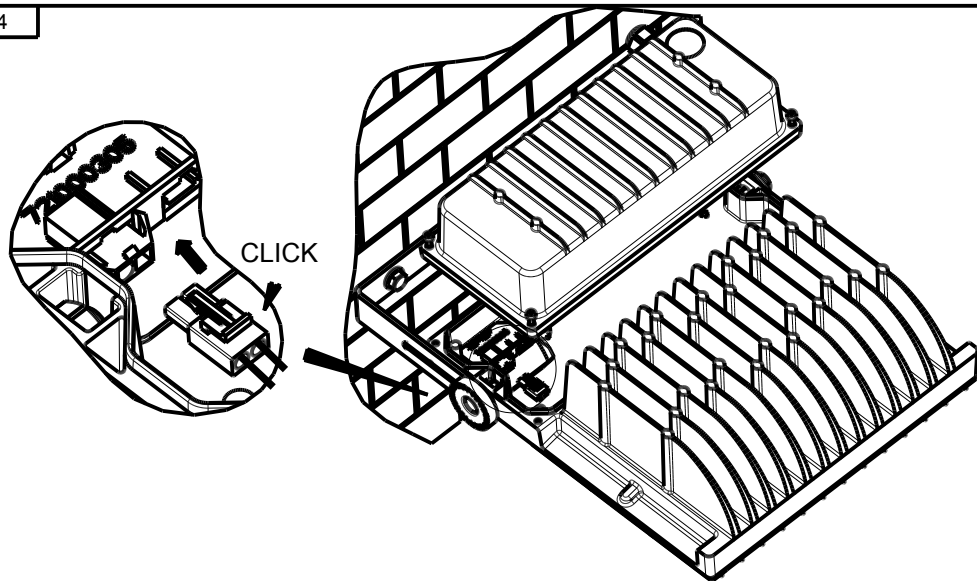

GRIGLIA PROTEZIONE
PROTECTION GRID

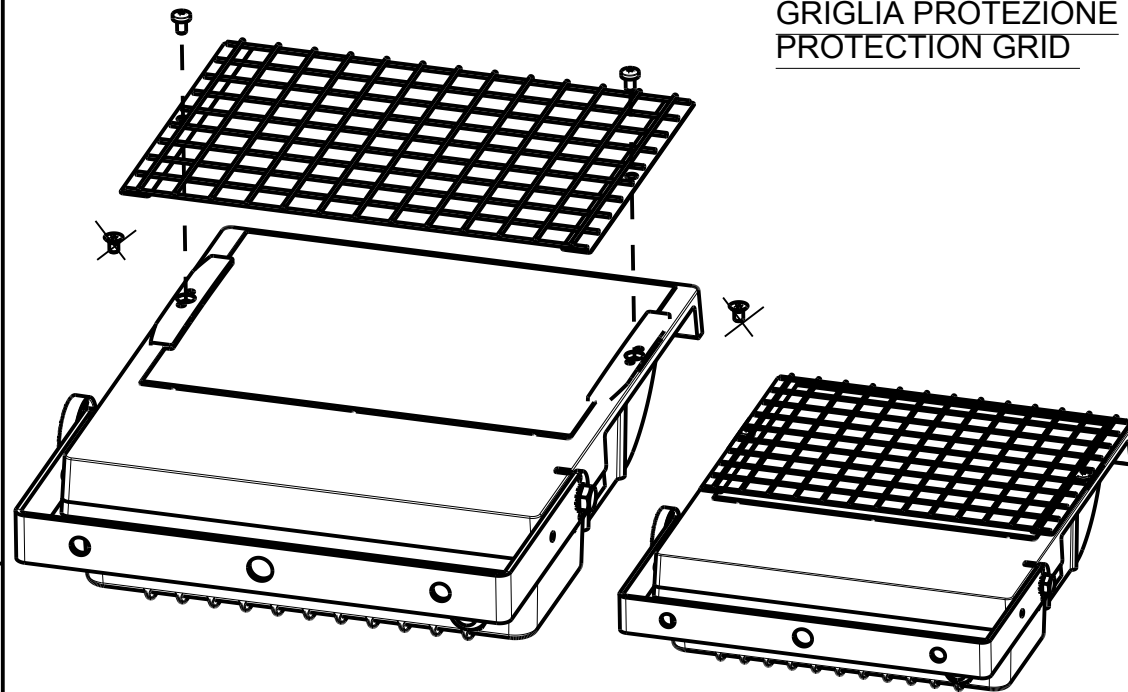

5

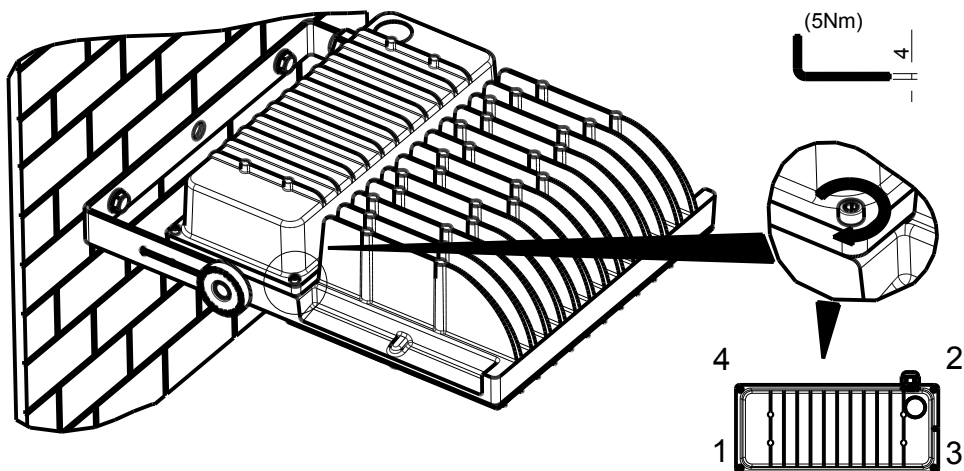

	9 LED	18 LED
Potenza totale Power total Puissance total Leistung gesamt Potencia total	78 W	150 W
Potenza LED Power LED Puissance LED Leistung LED Potencia LED	70 W	140 W

Gruppo di Rischio Esente
secondo norma EN 62471 - 2008
alla distanza di :
Risk group exempt according
to EN 62471: 2008 at a
distance of :

NEWTON A-D	2600 mm
NEWTON S-D	3800 mm

IT

EN

FR

DE

ES

L'installazione necessita l'intervento di personale specializzato.
Adatto per il funzionamento in interni
**ATTENZIONE!! PERICOLO DI SCOSSA ELETTRICA,
PRIMA DI EFFETTUARE OPERAZIONI DI MONTAGGIO
O MANUTENZIONE TOGLIERE LA TENSIONE.**
In caso di rottura del vetro l'apparecchio deve essere
riparato esclusivamente dal costruttore.
Conservare l'etichetta di imballo per l'identificazione
dell'apparecchio in caso di reclamo.

The installation must be carried out by qualified technicians.
Suitable for indoor use.
**WARNING!! DANGER OF ELECTRIC SHOCK, DISCONNECT
FROM ELECTRICAL SUPPLY DURING INSTALLATION OR
MAINTENANCE.**
In case of glass-fissure, the appliance should
be serviced only by the manufacturer.
Keep packing label to identify fitting, in case of claim.

L'installation doit être faite par personnel compétent.
Apte au fonctionnement à l'intérieur.
**ATTENTION!! DANGER DE CHOC ELECTRIQUE,
COUPER L ALIMENTATION ELECTRIQUE AVANT
INSTALLATION OU ENTRETIEN.**
En cas de rupture, l'appareil doit être réparé
que par le fabricant.
Garder l'étiquette emballage pour l'identification
de l'appareil en cas de réclamation.

Die Installation soll von Fachpersonal gemacht werden.
Geeignet für die Verwendung in Innenräumen.
**ACHTUNG!! GEFAHR VON ELEKTRISCHER SCHLAG,
STROMNETZ TRENNEN VOR INSTALLATION ODER
BEI WARTUNGSARBEITEN.**
Im Falle eines Glasbruchs, sollte das Gerät nur vom
Hersteller bedient werden.
Die Behalten Sie Verpackungsetikette für die Identifizie-
rung des Geräts falls es eine Beanstandung entsteht.

La instalacion necesita la intervencion de personal especializado.
Apropiado para uso interno.
**ATTENCION!! POR PELIGRO DE DESCARGA ELECTRICA,
ANTES DE EFECTUAR UNA OPERACION DE MONTAJE O
MANUTENCION, DESCONNECTAR LA CORRIENTE
ELECTRICA.**
En caso de rotura de vidrio, el aparato debe ser reparado
por el fabricante.
Conservar la etiqueta del embalaje para identificar al aparato
en caso de reclamacion.

VIA DELLA TECNICA 19
I-23875 OSNAGO (LC)
TEL. 039/587506
FAX 039/9520006

VIA PRATO 22
I-38068 ROVERETO (TN)
TEL. 0464/422247
FAX 0464/430393

VIA DELLA TECNICA 19
I-23875 OSNAGO (LC)
TEL. 039/9521.1
FAX 039/587812

COD. 207083390 (02.07.14)

www.carbonigroup.com 2/2